

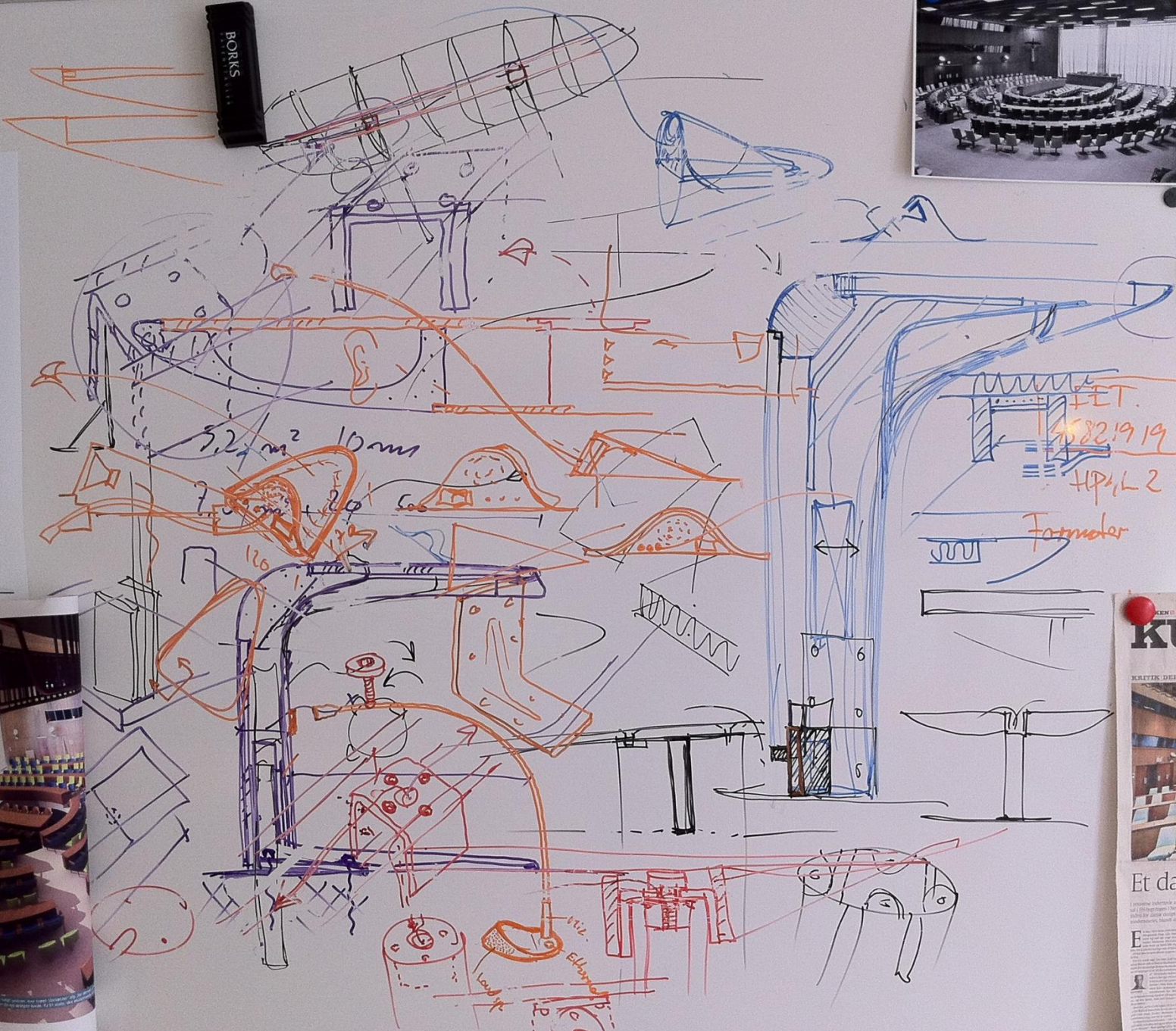



BORKS
STYRE



F.T.
1582,19 19
HP/L 2 -
Formoter



Ling... den... plan...
Lig... af...
Lig... af...
Lig... af...

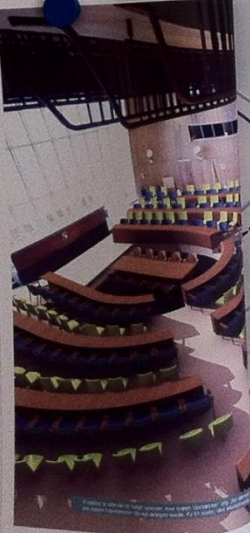

KULTUR



Et dansk ikon

Et dansk ikon
E

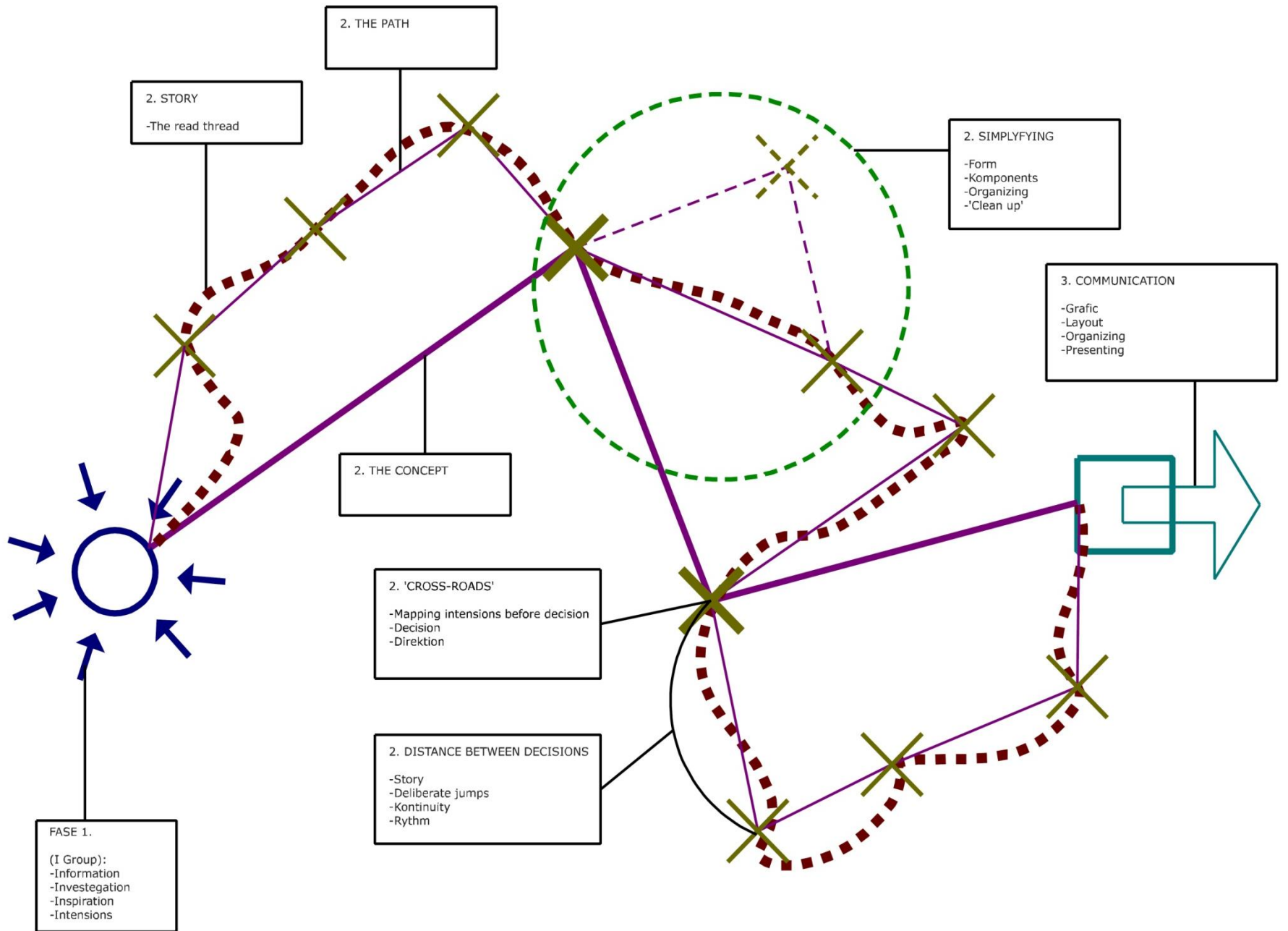

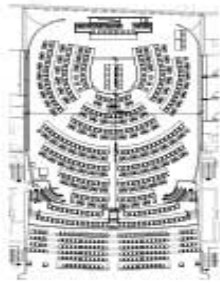

Finn Juhl hall

Sustainability



Meeting chairs



UN



Meeting tables



Meeting situation



Production



Finn Juhl





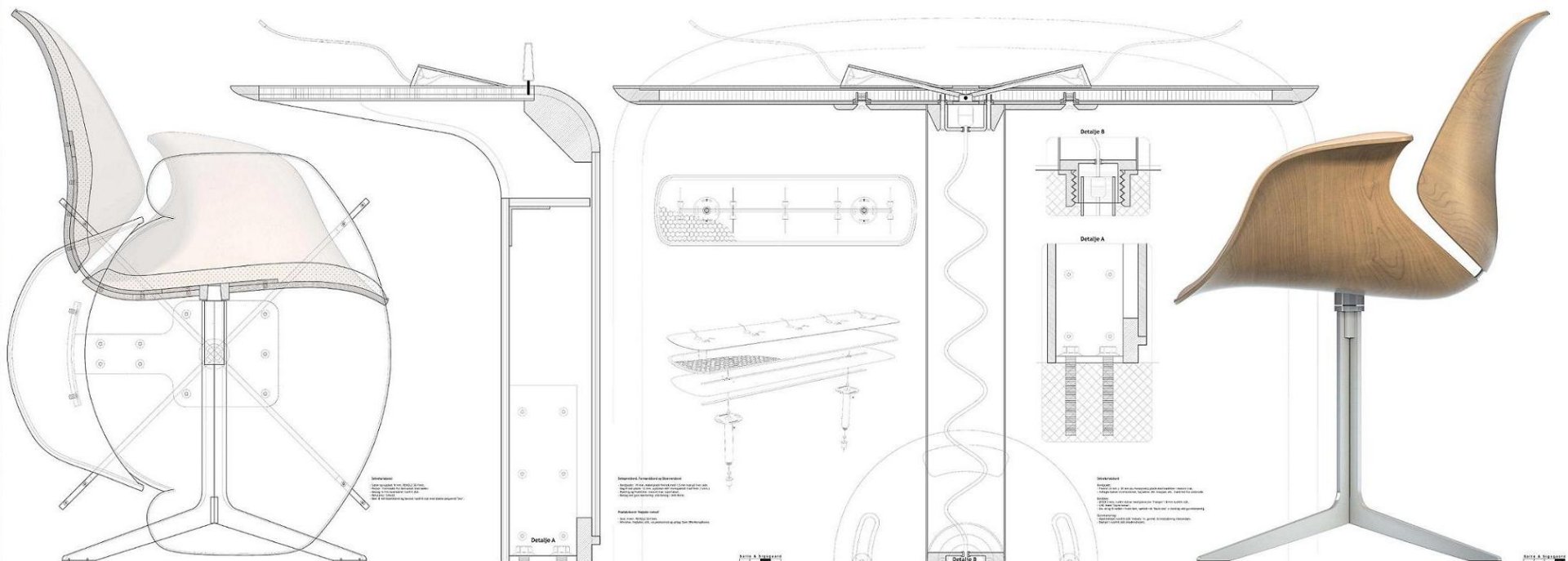

Ny dansk møbelkatalog til PM i New York

Designgenererende faktorer

Figur 1: Møbelkatalog

Figur 2: Møbelkatalog

Figur 3: Møbelkatalog

Figur 4: Møbelkatalog

Figur 5: Møbelkatalog

Figur 6: Møbelkatalog

Figur 7: Møbelkatalog

Figur 8: Møbelkatalog

Figur 9: Møbelkatalog

Figur 10: Møbelkatalog

Figur 11: Møbelkatalog

Figur 12: Møbelkatalog

Figur 13: Møbelkatalog

Figur 14: Møbelkatalog

Figur 15: Møbelkatalog

Figur 16: Møbelkatalog

Figur 17: Møbelkatalog

Figur 18: Møbelkatalog

Figur 19: Møbelkatalog

Figur 20: Møbelkatalog

Figur 21: Møbelkatalog

Figur 22: Møbelkatalog

Figur 23: Møbelkatalog

Figur 24: Møbelkatalog

Figur 25: Møbelkatalog

Figur 26: Møbelkatalog

Figur 27: Møbelkatalog

Figur 28: Møbelkatalog

Figur 29: Møbelkatalog

Figur 30: Møbelkatalog

Figur 31: Møbelkatalog

Figur 32: Møbelkatalog

Figur 33: Møbelkatalog

Figur 34: Møbelkatalog

Figur 35: Møbelkatalog

Figur 36: Møbelkatalog

Figur 37: Møbelkatalog

Figur 38: Møbelkatalog

Figur 39: Møbelkatalog

Figur 40: Møbelkatalog

Figur 41: Møbelkatalog

Figur 42: Møbelkatalog

Figur 43: Møbelkatalog

Figur 44: Møbelkatalog

Figur 45: Møbelkatalog

Figur 46: Møbelkatalog

Figur 47: Møbelkatalog

Figur 48: Møbelkatalog

Figur 49: Møbelkatalog

Figur 50: Møbelkatalog

Figur 51: Møbelkatalog

Figur 52: Møbelkatalog

Figur 53: Møbelkatalog

Figur 54: Møbelkatalog

Figur 55: Møbelkatalog

Figur 56: Møbelkatalog

Figur 57: Møbelkatalog

Figur 58: Møbelkatalog

Figur 59: Møbelkatalog

Figur 60: Møbelkatalog

Figur 61: Møbelkatalog

Figur 62: Møbelkatalog

Figur 63: Møbelkatalog

Figur 64: Møbelkatalog

Figur 65: Møbelkatalog

Figur 66: Møbelkatalog

Figur 67: Møbelkatalog

Figur 68: Møbelkatalog

Figur 69: Møbelkatalog

Figur 70: Møbelkatalog

Figur 71: Møbelkatalog

Figur 72: Møbelkatalog

Figur 73: Møbelkatalog

Figur 74: Møbelkatalog

Figur 75: Møbelkatalog

Figur 76: Møbelkatalog

Figur 77: Møbelkatalog

Figur 78: Møbelkatalog

Figur 79: Møbelkatalog

Figur 80: Møbelkatalog

Figur 81: Møbelkatalog

Figur 82: Møbelkatalog

Figur 83: Møbelkatalog

Figur 84: Møbelkatalog

Figur 85: Møbelkatalog

Figur 86: Møbelkatalog

Figur 87: Møbelkatalog

Figur 88: Møbelkatalog

Figur 89: Møbelkatalog

Figur 90: Møbelkatalog

Figur 91: Møbelkatalog

Figur 92: Møbelkatalog

Figur 93: Møbelkatalog

Figur 94: Møbelkatalog

Figur 95: Møbelkatalog

Figur 96: Møbelkatalog

Figur 97: Møbelkatalog

Figur 98: Møbelkatalog

Figur 99: Møbelkatalog

Figur 100: Møbelkatalog



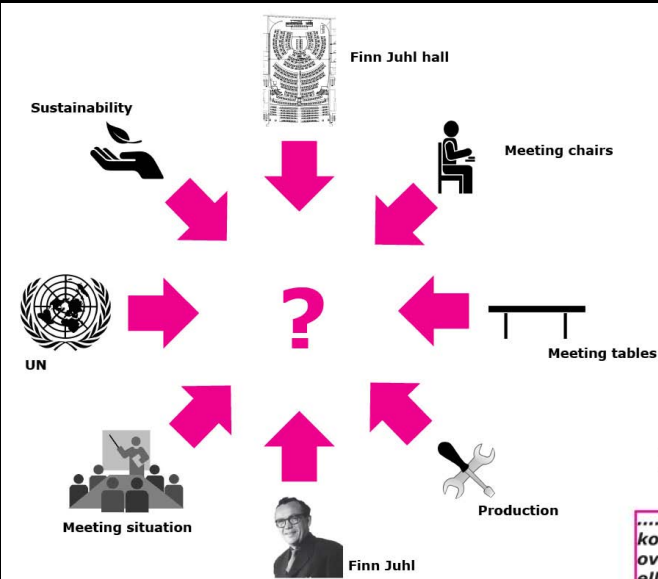

Diagram A - Udskrivers intensjoner, krav og ønsker

....Det er dog af afgørende betydning, at konkurrenceforslaget **forholder sig** til salens overordnede udtryk og **harmonerer** med og/ eller **supplerer** salens karakterfulde udtryk, hvad gælder form, materialer, farver og detaljering og dermed medvirker til salens designmæssige sammenhæng og kontinuitet

....Det er dog af afgørende betydning, at konkurrenceforslaget **forholder sig** til salens overordnede udtryk og **harmonerer** med og/ eller **supplerer** salens karakterfulde udtryk, hvad gælder form, materialer, farver og detaljering og dermed medvirker til salens designmæssige sammenhæng og kontinuitet

....Det er blevet besluttet at renovere hele bygningen og føre den tilbage til dens oprindelige udtryk med anvendelser af materialer og teknik, som opfylder det 21. århundredes fordringer.

....Det er blevet besluttet at renovere hele bygningen og føre den tilbage til dens **oprindelige udtryk** med anvendelser af materialer og teknik, som opfylder det 21. århundredes fordringer.

....Forslaget vil i forlængelse af Finn Juhls design også blive bedømt ud fra, hvordan det bidrager til salens rumlige koncept

....Forslaget vil i forlængelse af Finn Juhls design også blive bedømt ud fra, hvordan det **bidrager** til salens rumlige koncept

....Sekretariatstolen skal **korrespondere** med den oprindelige Finn Juhl-stol (FJ51), som er en betrukket stol og som i forbindelse med restaureringen af salen bliver nyproduceret....

....Sekretariatstolen skal **korrespondere** med den oprindelige Finn Juhl-stol (FJ51), som er en betrukket stol og som i forbindelse med restaureringen af salen bliver nyproduceret....

....Forslaget må gerne være rumligt nyskabende og kontrastere det oprindelige design, men skal samtidig tage hensyn til hovedgrebet i udformningen af salen og salens oprindelige idé og dermed bidrage til det samlede indtryk af salen.

....Forslaget må gerne være **rumligt nyskabende** og **kontrastere** det oprindelige design, men skal samtidig **tage hensyn** til **hovedgrebet** i udformningen af salen og salens oprindelige idé og dermed **bidrage** til det samlede indtryk af salen.

....Stol og borde skal fremtræde som klare nutidige eksponenter for dansk møbelkunst, her set i en historisk kontekst.

....Stol og borde skal fremtræde som klare **nutidige eksponenter** for dansk møbelkunst, her set i en historisk kontekst.

....Konkurrenceforslaget (stol og borde) skal **adskille sig** fra Finn Juhl-salens oprindelige stole og borde.

....Konkurrenceforslaget (stol og borde) skal **adskille sig** fra Finn Juhl-salens oprindelige stole og borde.



Forholde



Adskille

Forholde



Adskille



Finn Juhl hall



Sustainability



Meeting chairs



UN



Meeting tables



Meeting situation



Production



Finn Juhl

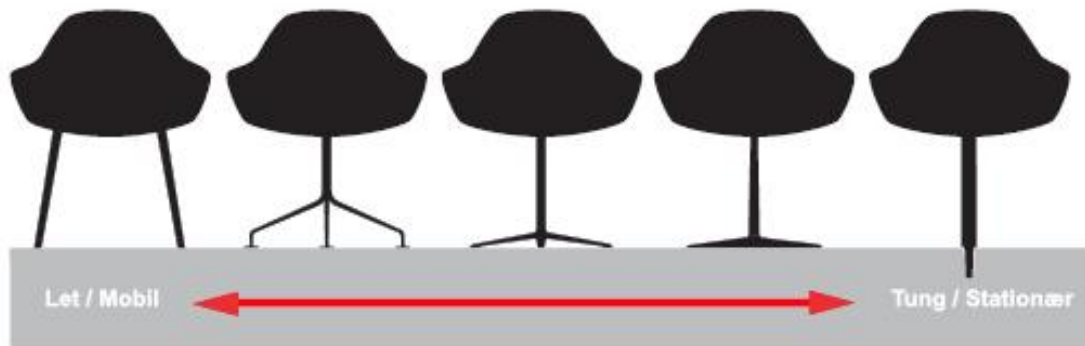

Mobil stol, let / håndterbar

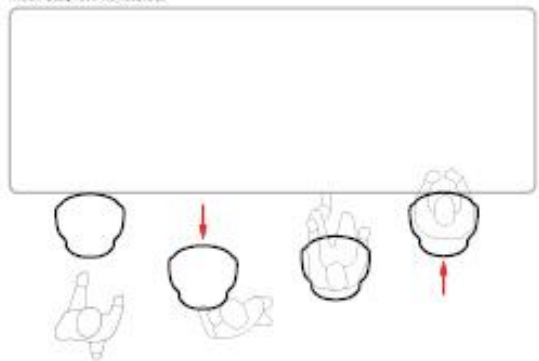

Stationær stol med drej

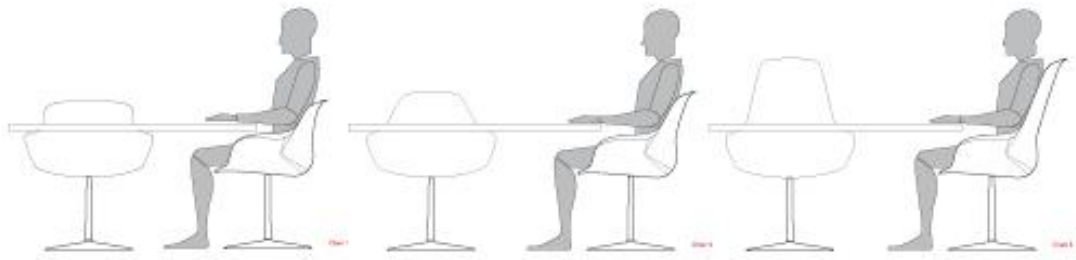
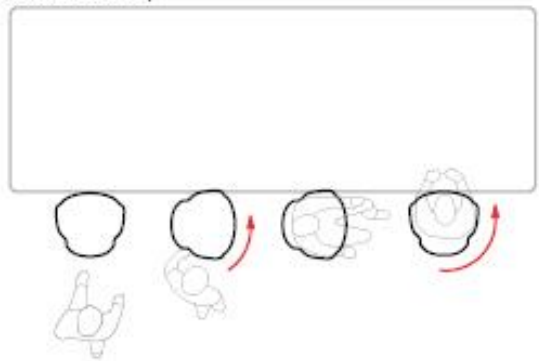



Finn Juhl hall

Sustainability



Meeting chairs



UN



Meeting tables



Meeting situation



Production



Finn Juhl







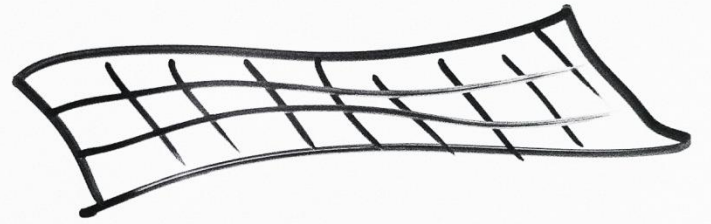

Scale model

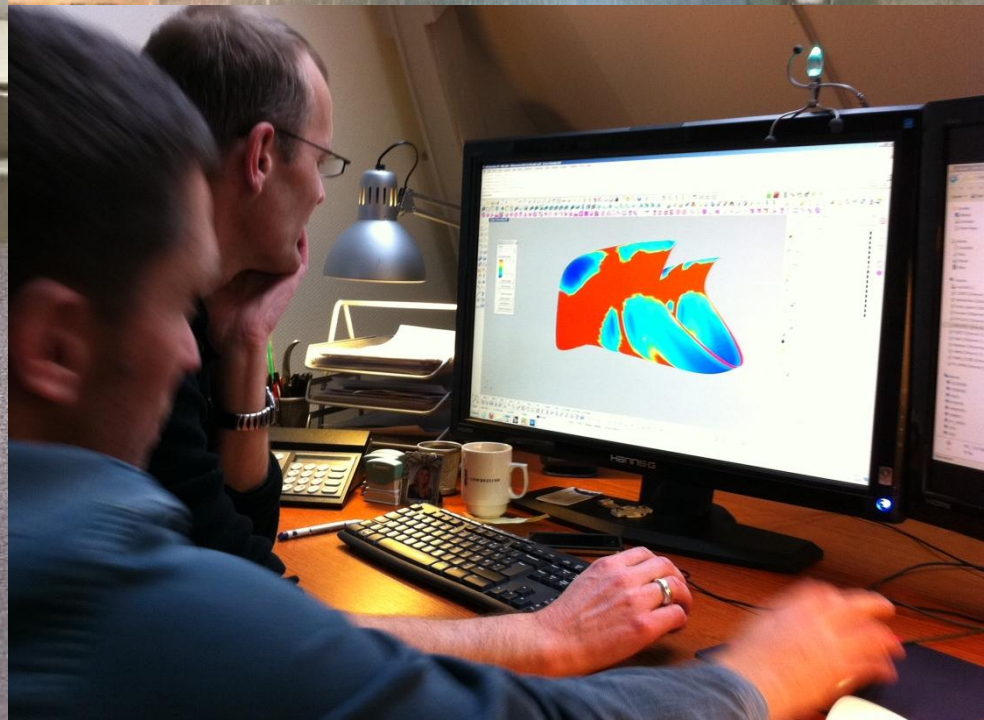



e Furniture

Plan layout 1:50

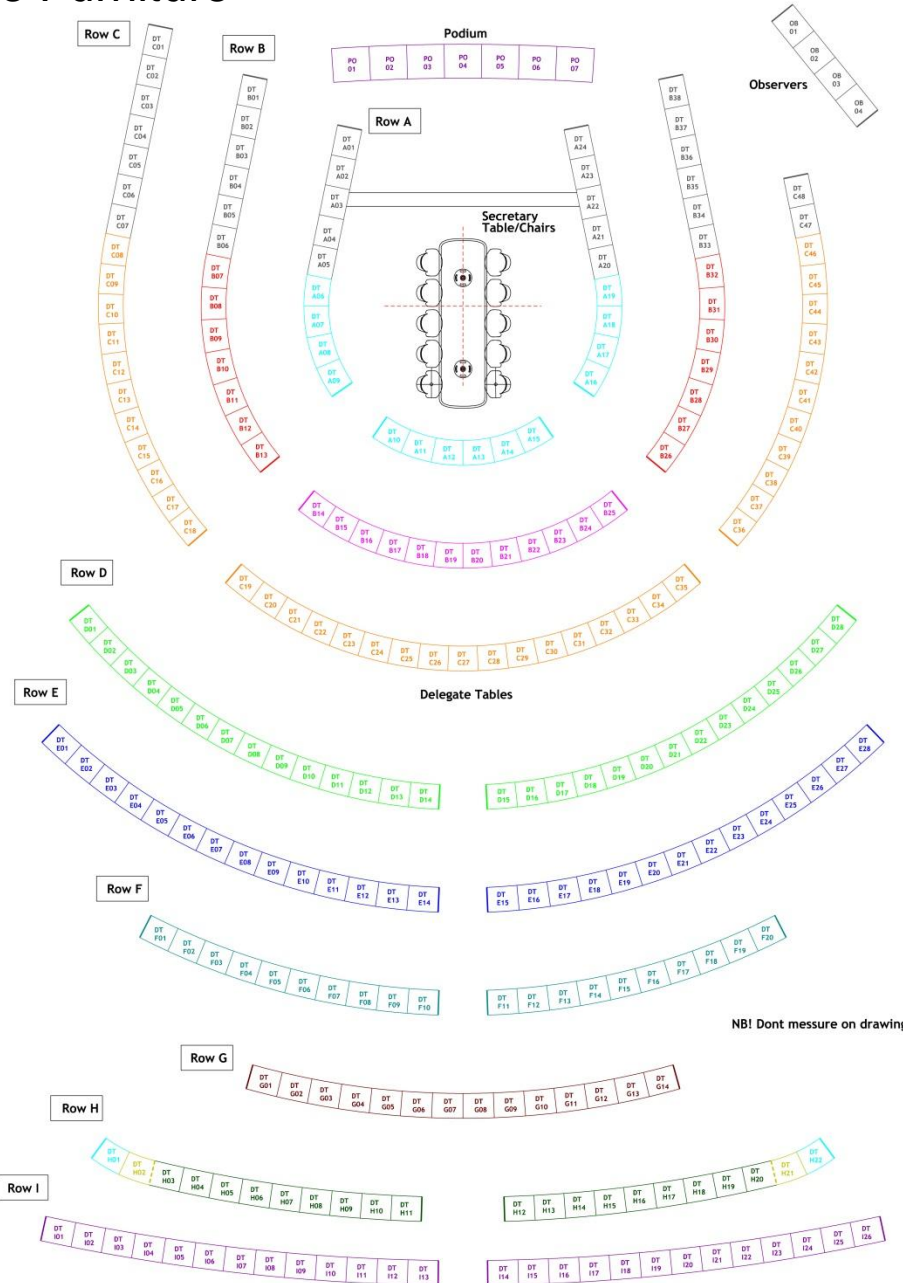

Mould 1
Straight.
(35 Units)

Mould 2
Radius:
3019,68 mm.
(18 Units)

Mould 3
Radius:
5331,08 mm.
(26 Units)

Mould 4
Radius:
7642,48 mm.
(39 Units)

Mould 5
Radius:
10766,68 mm.
(28 Units)

Mould 6
Radius:
13078,08 mm.
(28 Units)

Mould 7
Radius:
15389,48 mm.
(18 Units)

Mould 8
Radius:
17700,88 mm.
(14 Units)

Mould 9
Radius:
29464,30 mm.
(18 Units)

Mould 10
Radius:
44759,91 mm.
(33 Units)

NB! Dont measure on drawing.

Overview, Units 1:50

Overview, Plywood 1:25

<ul style="list-style-type: none"> 2 Units 1 Left-Unit 1 Right-Unit 		4 Units	Details - Look at drawing: D-ot 4.001.dwg/pdf D-ot 4.101.igs (CNC)
<ul style="list-style-type: none"> 25 Units 3 Left-Units 3 Right-Units 		31 Units	Details - Look at drawing: D-dt 2.001.dwg/pdf D-dt 2.101.igs (CNC)
<ul style="list-style-type: none"> 12 Units 2 Left-Units 2 Right-Units 		14 Units	Details - Look at drawing: D-dt 2.002.dwg/pdf D-dt 2.102.igs (CNC)
<ul style="list-style-type: none"> 1 Left-Unit 1 Right-Unit 1 Unit (H2) 1 Unit (H2.1) 		2 Units	Details - Look at drawing: D-dt 2.002.dwg/pdf D-dt 2.102.igs (CNC)
<ul style="list-style-type: none"> 12 Units 1 Left-Unit 1 Right-Unit 10 Units 1 Left-Unit 1 Right-Unit 		14 Units	Details - Look at drawing: D-dt 2.004.dwg/pdf D-dt 2.104.igs (CNC)
<ul style="list-style-type: none"> 35 Units 2 Left-Units 2 Right-Units 		12 Units	Details - Look at drawing: D-dt 2.005.dwg/pdf D-dt 2.105.igs (CNC)
<ul style="list-style-type: none"> 24 Units 2 Left-Units 2 Right-Units 		39 Units	Details - Look at drawing: D-dt 2.006.dwg/pdf D-dt 2.106.igs (CNC)
<ul style="list-style-type: none"> 24 Units 2 Left-Units 2 Right-Units 		28 Units	Details - Look at drawing: D-dt 2.007.dwg/pdf D-dt 2.107.igs (CNC)
<ul style="list-style-type: none"> 16 Units 2 Left-Units 2 Right-Units 		28 Units	Details - Look at drawing: D-dt 2.008.dwg/pdf D-dt 2.108.igs (CNC)
<ul style="list-style-type: none"> 16 Units 2 Left-Units 2 Right-Units 		20 Units	Details - Look at drawing: D-dt 2.009.dwg/pdf D-dt 2.109.igs (CNC)
<ul style="list-style-type: none"> 12 Units 1 Left-Unit 1 Right-Unit 		14 Units	Details - Look at drawing: D-dt 2.010.dwg/pdf D-dt 2.110.igs (CNC)
<ul style="list-style-type: none"> 16 Units 1 Left-Unit 1 Right-Unit 		18 Units	Details - Look at drawing: D-dt 2.011.dwg/pdf D-dt 2.111.igs (CNC)
<ul style="list-style-type: none"> 22 Units 2 Left-Unit 2 Right-Unit 		26 Units	Details - Look at drawing: D-dt 2.012.dwg/pdf D-dt 2.112.igs (CNC)
<ul style="list-style-type: none"> 5 Units 1 Left-Unit 1 Right-Unit 		7 Units	Details - Look at drawing: D-pt 3.001.dwg/pdf D-pt 3.101.igs (CNC)
Total: 259 Units			

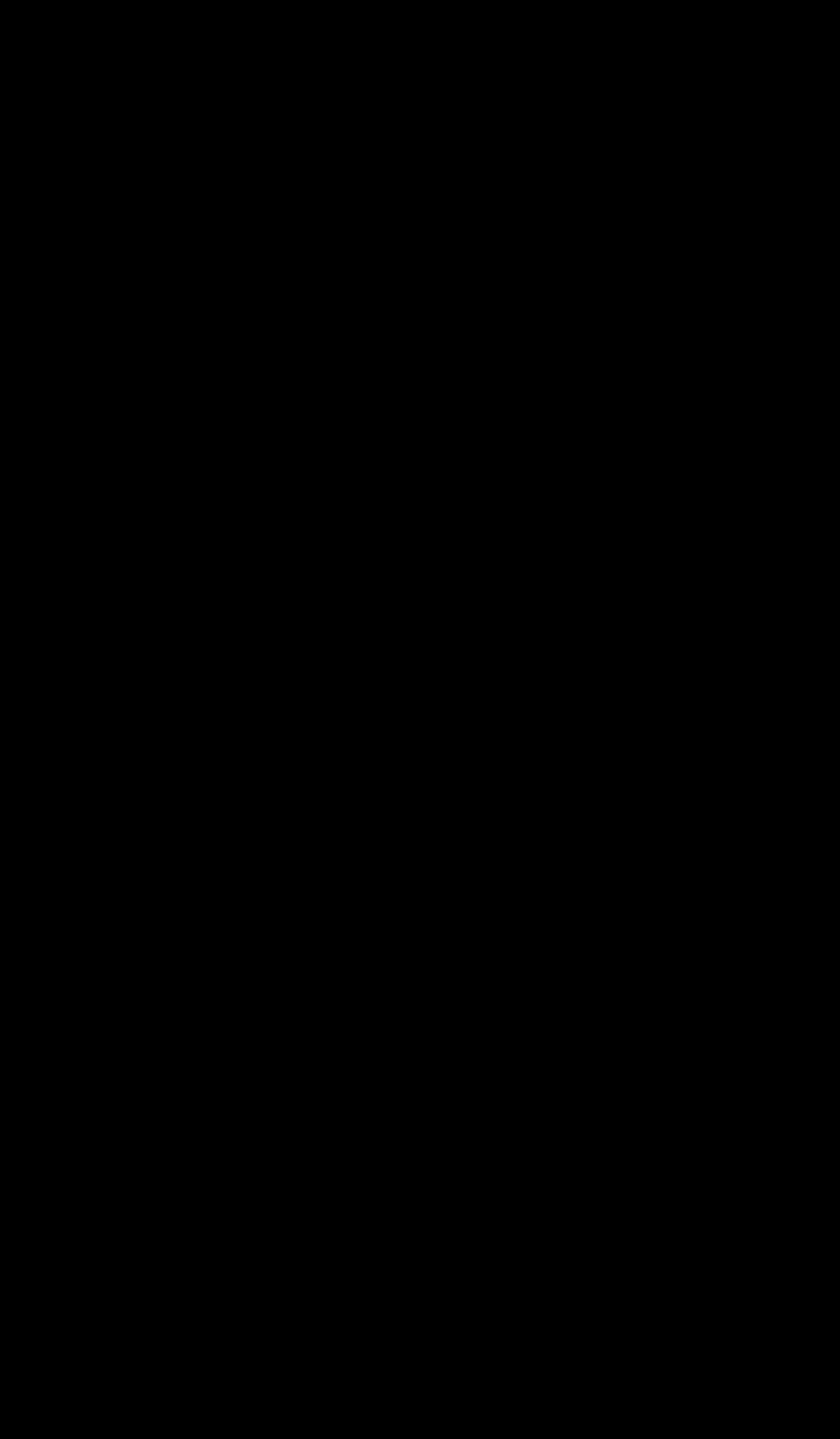

Delegate Table, final drawing

UNITED NATIONS Trusteeship Council Chamber - Marmatten - New York

Title: Delegate table Row H1 Drawing NO: D-B2.005

Scale: DWG 1:1 Drawing 1:2 Date: 2012/19

Note: The sides are angle to fit together with DT 100 and DT 102
NB: DT 100 is mirrored from this unit

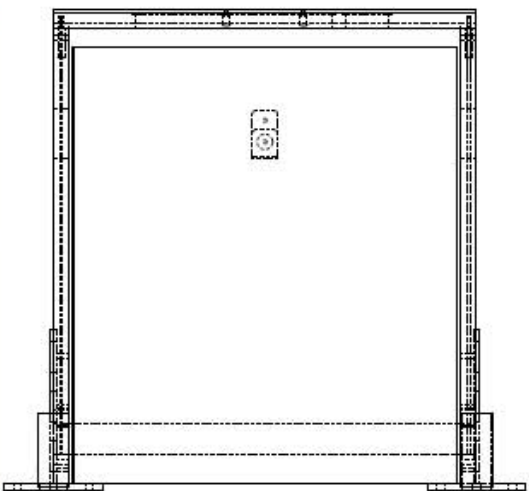
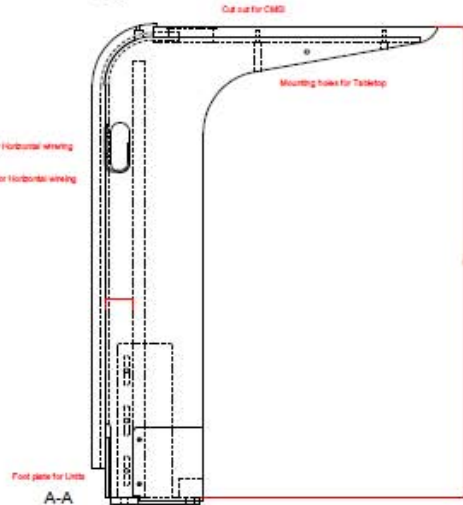
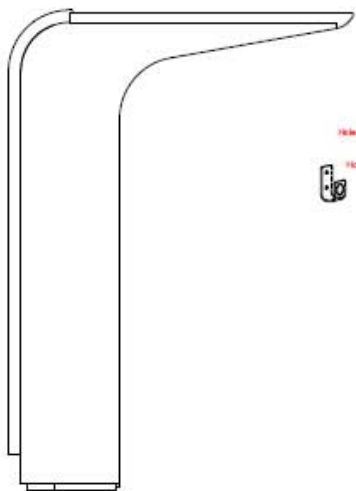
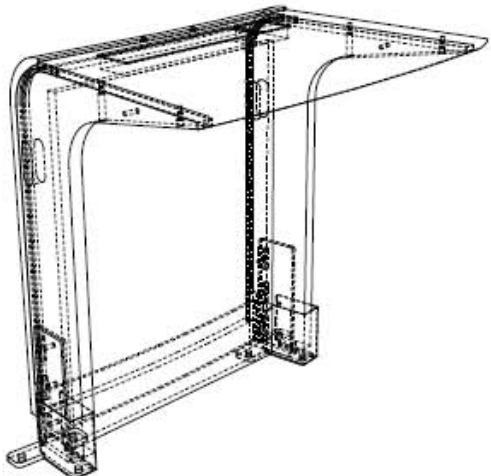
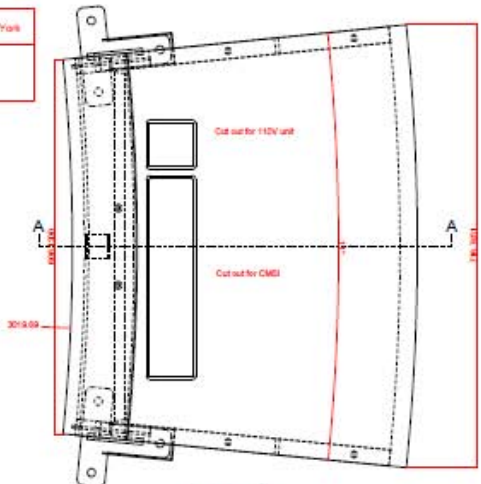







The Museum of Modern Art
MOMA

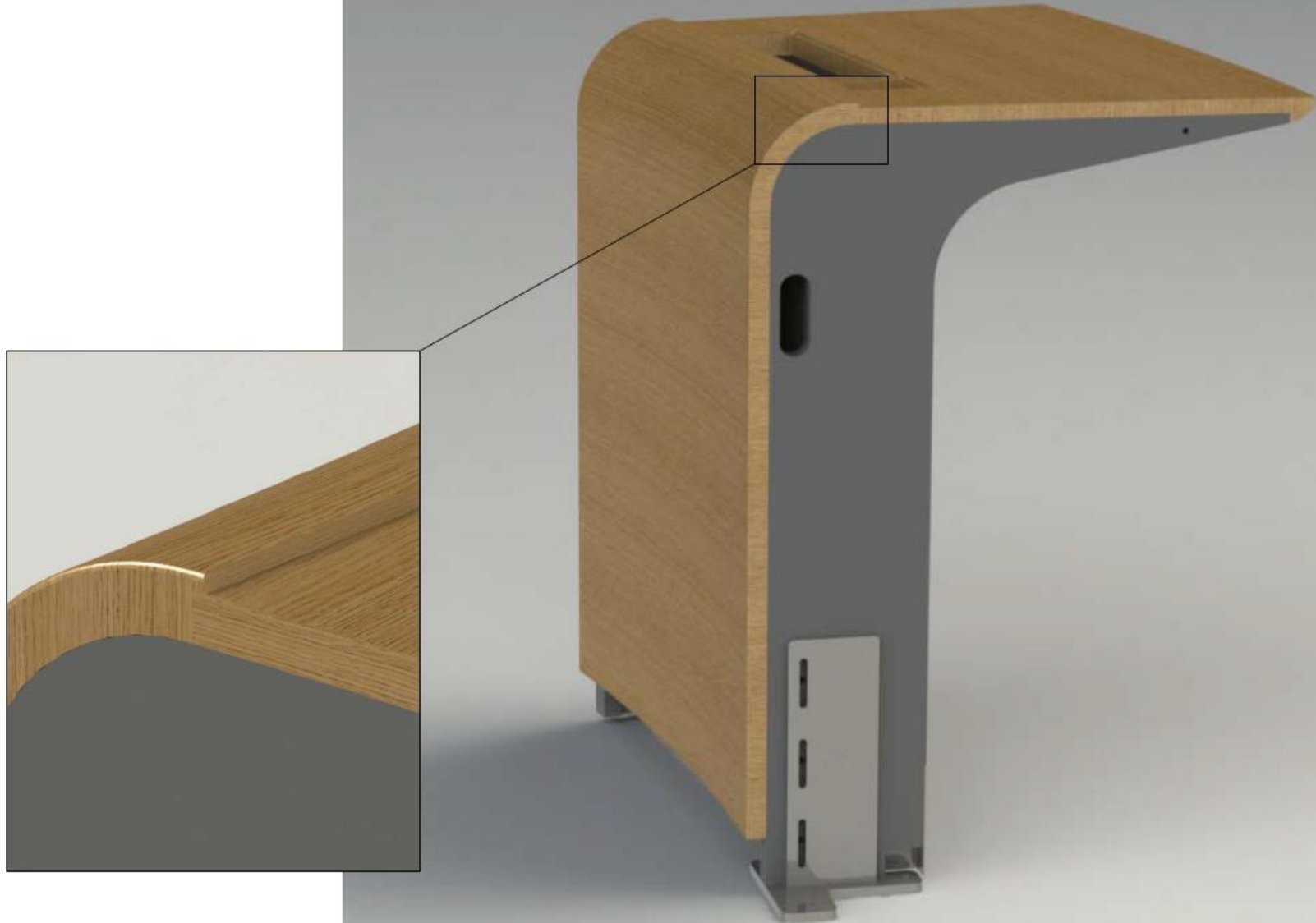

G	LE
S	T



Concept
Context
Size
Time
Development

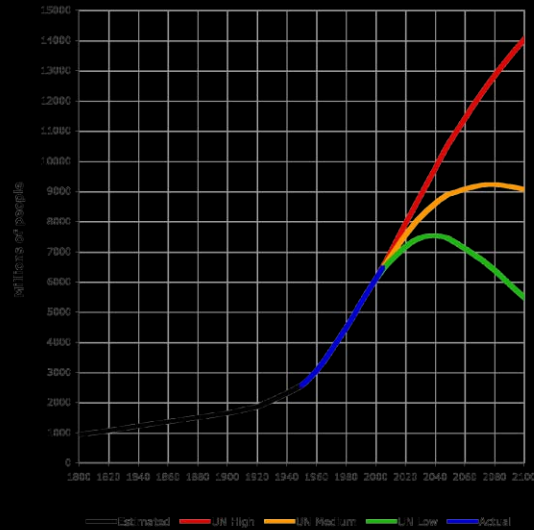

**The urban residents of the world
will double in 38 years**

Concept
Context
Size
Time
Development

designboom illustrated folding chairs history



Concept

Context

Size

Time

Development



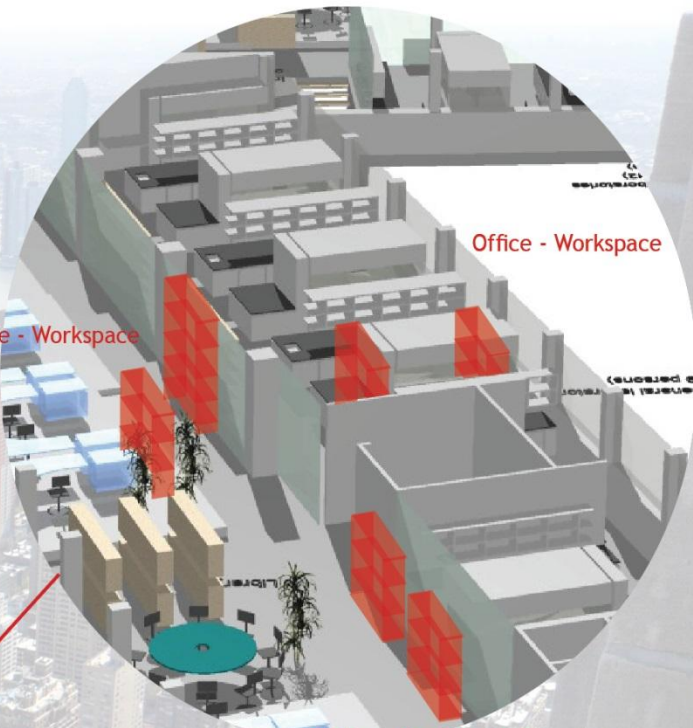
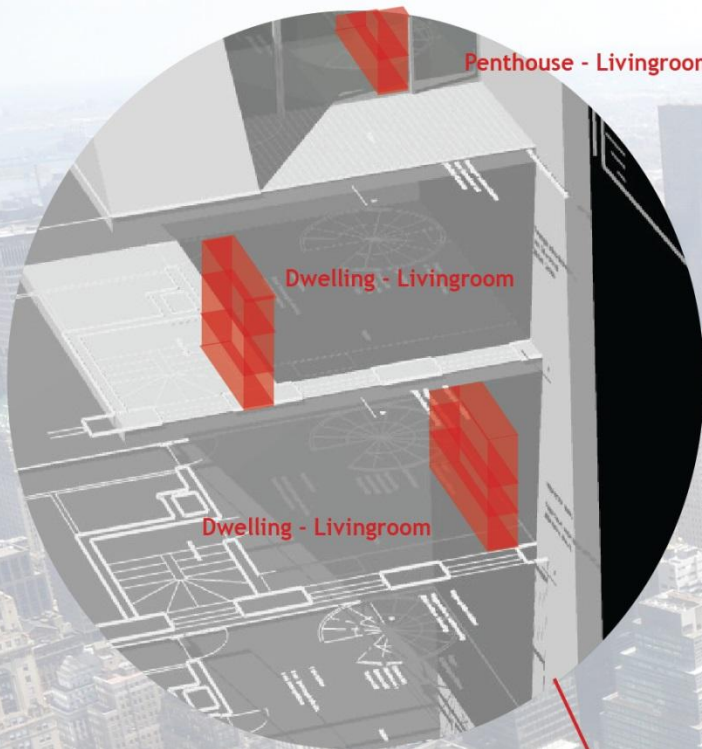

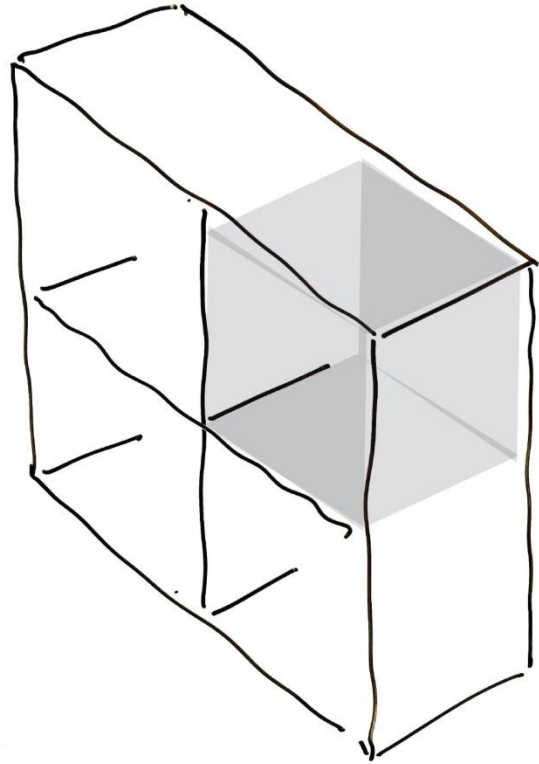

Concept

Context

Size

Time

Development

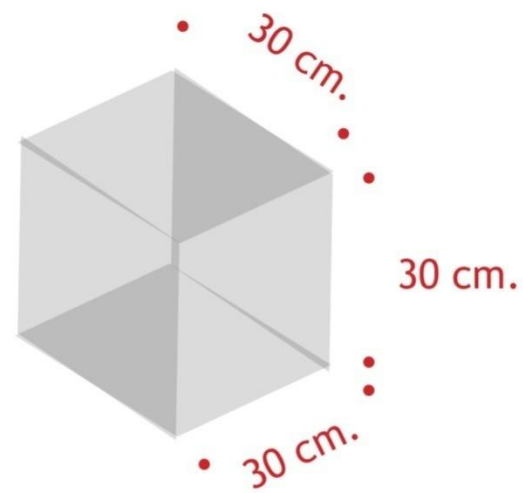

Concept

Context

Size

Time

Development



- 30 cm.
- (To low!)

Concept

Context

Size

Time

Development



•
48 cm. !

(Normal chair height!)
•

Concept

Context

Size

Time

Development

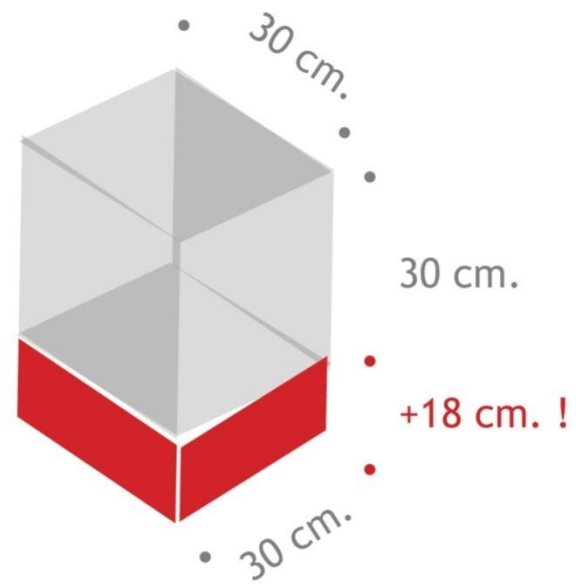

Concept
Context
Size
Time
Development

1 second...



Concept
Context
Size
Time
Development

2 seconds...



Concept
Context
Size
Time
Development

3 seconds...



Concept
Context
Size
Time
Development

3,5 seconds...
(48cm!)



Concept
Context
Size
Time
Development

4 seconds...



Concept
Context
Size
Time
Development

5 seconds...



Concept
Context
Size
Time
Development

6 seconds...



Concept
Context
Size
Time
Development

Steel house: Nord for Herring
Sunds

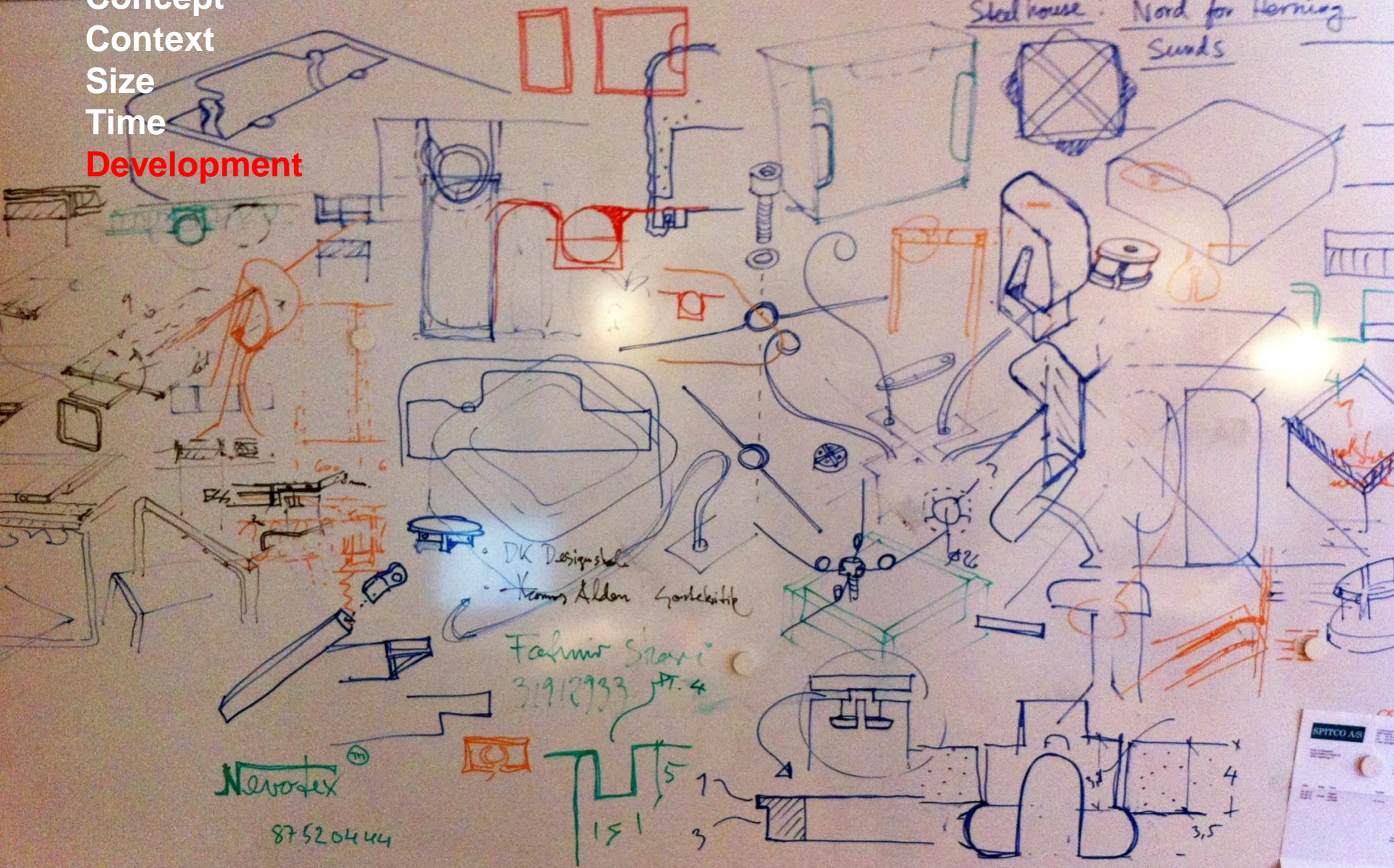

DK Designskole
Kenny Alden Gørdekittip

Fahim Smani
31912933 PT. 4

Nerovex
87520444

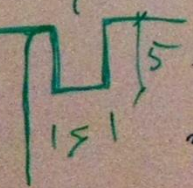

Concept
 Context
 Size
 Time
 Development

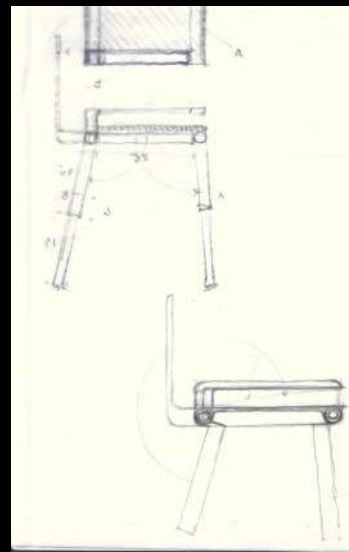
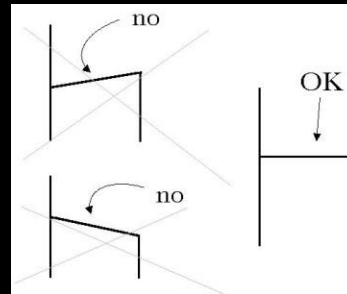
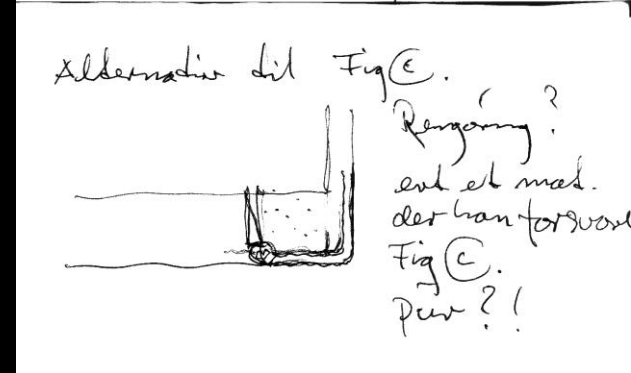
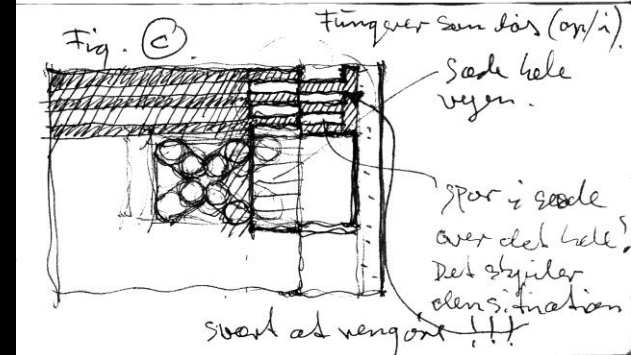
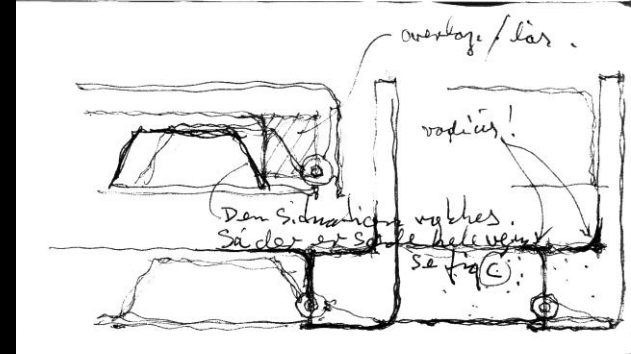
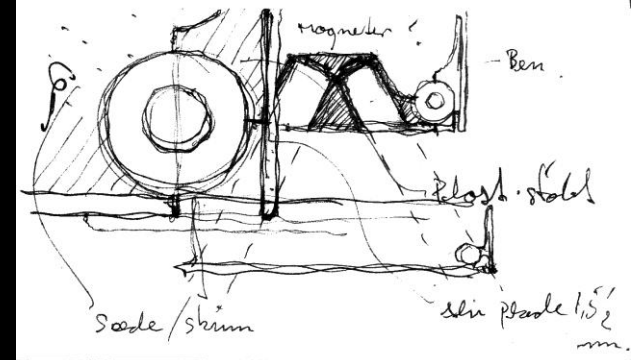

Concept
Context
Size
Time
Development



Concept
Context
Size
Time
Development

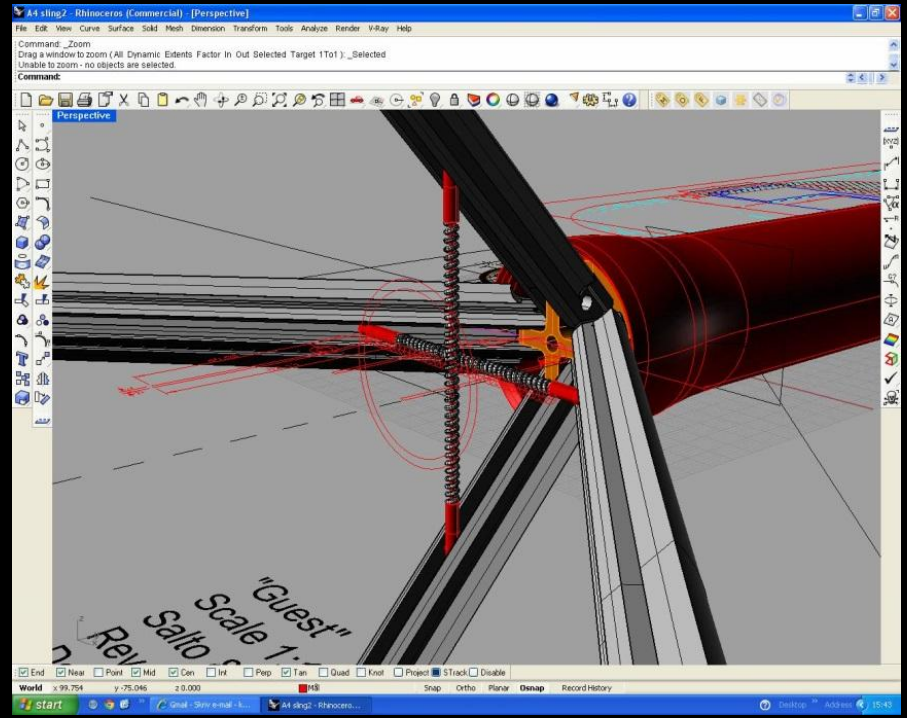
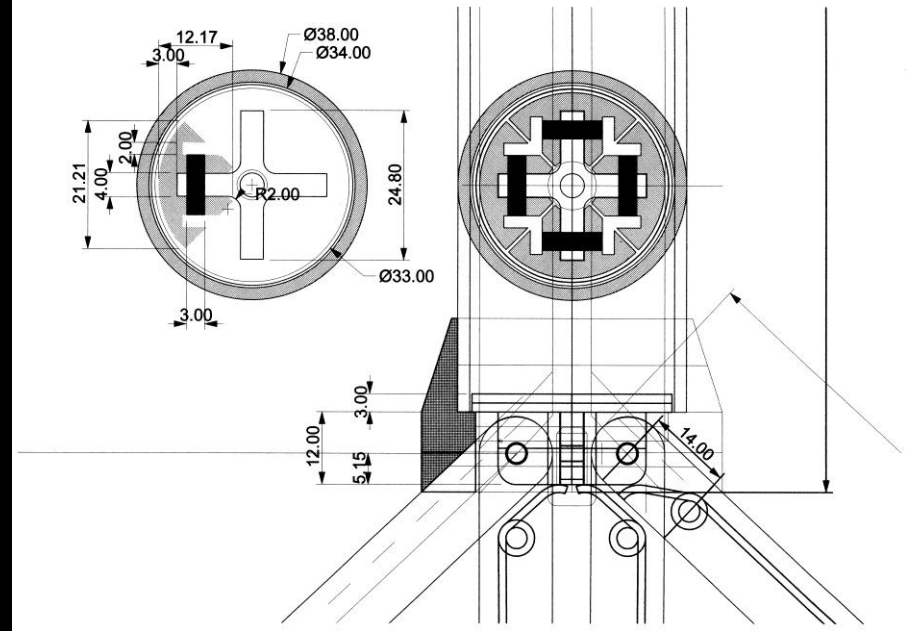

Concept
Context
Size
Time
Development



UNLESS OTHERWISE SPECIFIED	FINISH	SCALE AND DIMENSIONS	DATE AND DRAWN BY	REVISION
DIMENSIONS ARE IN MILLIMETERS UNLESS OTHERWISE SPECIFIED UNLESS OTHERWISE SPECIFIED UNLESS OTHERWISE SPECIFIED				
DRAWN: _____ CHECKED: _____ APPROVED: _____ DATE: _____	NAME: _____ SIGNATURE: _____ DATE: _____	TITLE: _____	DO NOT SCALE DRAWING	REVISION

Concept
Context
Size
Time
Development



oland

MDX-650

- Concept
- Context
- Size
- Time
- Development

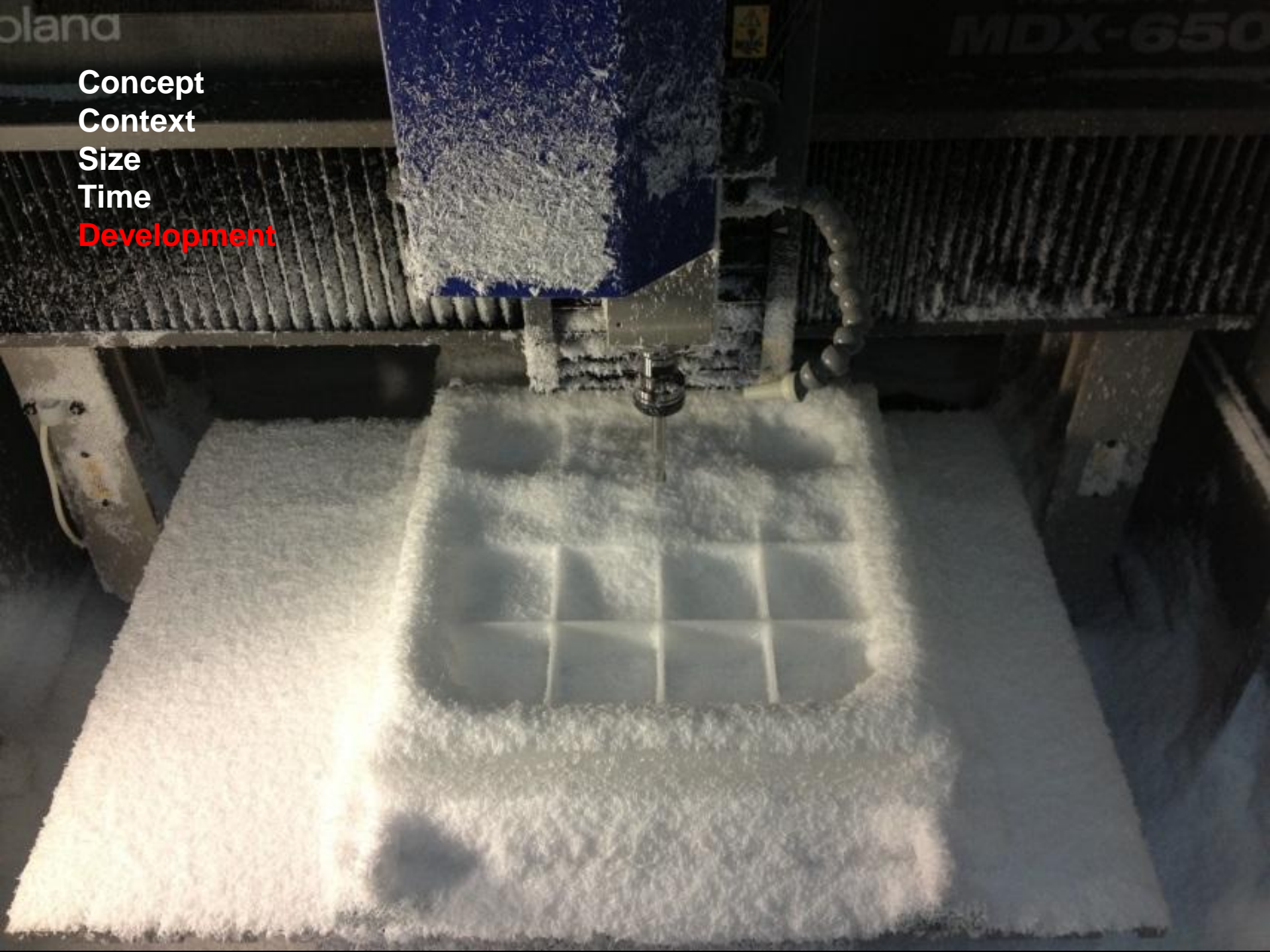

Concept
Context
Size
Time
Development



47 Parts

